



REL

REL
ACOUSTICS LTD.



Operating Instructions for the

Planar Sub-Bass System

Caution Marking Explanation



The lightning flash with arrowhead symbol within an equilateral triangle is intended to alert the user to the presence of un-insulated dangerous voltage within the product's enclosure that may be of sufficient magnitude to constitute a risk of electric shock to persons.



The exclamation point within an equilateral triangle is intended to alert the user to the presence of important operating and maintenance (servicing) instructions in the literature accompanying the appliance.

Important Safety Instructions

- 1 Read all of these instructions.
- 2 Save these instructions for future use.
- 3 Heed all warnings.
- 4 Follow all instructions.
- 5 Do not use this apparatus near water.
- 6 Clean only with automotive polish and micro fiber cloth.
- 7 Install in accordance with the manufacturer's instructions.
- 8 Do not install near any heat sources such as radiators, heat registers, stoves or other apparatus (including amplifiers) that produce heat.
- 9 Do not defeat the safety purpose of the grounding-type plug. A grounding type plug has two blades and a third grounding prong. The third prong is provided for your safety. If the provided plug does not fit into your outlet, consult an electrician for replacement of the obsolete outlet.
- 10 Protect the power cord from being walked on or pinched particularly at plugs, convenience receptacles, and the point where they exit from the apparatus.
- 11 Only use attachments/accessories specified by the manufacturer.
- 12 Use only with a cart, stand, tripod, bracket, or table specified by the manufacturer, or sold with the apparatus. When a cart is used, use caution when moving the cart/apparatus combination to avoid injury from tip-over.

- 13 Unplug this apparatus during lightning storms or when unused for long periods of time.
- 14 Refer all servicing to qualified service personnel. Servicing is required when the apparatus has been damaged in any way, such as power-supply cord or plug is damaged, liquid has been spilled or objects have fallen into the apparatus, the apparatus has been exposed to rain or moisture, does not operate normally, or has been dropped.
- 15 Minimum distances 10cm around the apparatus for sufficient ventilation.

- 16 The ventilation should not be impeded by covering the ventilation openings with items, such as newspapers, table-cloths, curtains, etc.
- 17 No naked flame sources, such as lighted candles, should be placed on the apparatus.
- 18 Attention should be drawn to the environmental aspects of battery disposal.
- 19 The use of apparatus in moderate climates.
- 20 Batteries shall not be exposed to excessive heat such as sunshine, fire or the like.

Caution: *Any changes or modifications not expressly approved by the party responsible for compliance could void the user's authority to operate this equipment.*

Warning

To reduce the risk of fire or electric shock, do not expose this apparatus to rain or moisture.

The apparatus shall not be exposed to dripping or splashing and no objects filled with liquids, such as vases, shall be placed on apparatus.

The mains plug is used as disconnect device. The mains plug of the apparatus should not be obstructed OR should be easily accessed during intended use. To be completely disconnected from the power input, the mains plug of the apparatus shall be disconnected from the mains.

An appliance with a protective earth terminal should be connected to a mains outlet with a protective earth connection.

Design Safety

These apparatus are supplied with a detachable mains cord. For 230V operation an 4A fuse is fitted in the socket of the Planar PL-2 and a 2.5A fuse is fitted in the socket of the Planar PL-1, for 120V operation a 8A fuse is fitted for the Planar PL-2 and a 5A fuse is fitted for the Planar PL-1. Should the fuse need to be replaced use a similar rated fuse approved to ASTA or BSI 362 standards. Do not use without the fuse cover in place. Replacement fuse covers are available from your distributor.

Attention Explication Marquage



L'éclair avec le symbole de pointe de flèche dans un triangle équilatéral est destiné à alerter l'utilisateur de la présence de non isolée tension dangereuse à l'intérieur de l'enceinte du produit qui peut être d'une ampleur suffisante pour constituer un risque d'électrocution pour les personnes.



Le point d'exclamation dans un triangle équilatéral est destiné à alerter l'utilisateur de la présence d'instructions dans la documentation accompagnant l'appareil exploitation et de maintenance (entretien).

Informations Importantes Relatives a la Securite

- 1 Lisez attentivement ces instructions.
 - 2 Conservez ces instructions.
 - 3 Respectez tous les avertissements.
 - 4 Suivez toutes les instructions.
 - 5 Ne pas utiliser cet appareil près de l'eau.
 - 6 Nettoyez seulement avec du vernis automobile et tissu microfibre.
 - 7 Installer conformément aux instructions du fabricant.
 - 8 Ne pas installer près de sources de chaleur telles que des radiateurs, registres de chaleur, poêles ou autres appareils (y compris les amplificateurs) qui produisent de la chaleur.
 - 9 Ne pas contourner le dispositif de sécurité de la prise de terre. Une fiche de terre a deux lames et une troisième broche de mise à la terre. La troisième broche est fournie pour votre sécurité. Si la fiche fournie ne rentre pas dans votre prise, consultez un électricien pour le remplacement de la prise obsolète.
 - 10 Protégez le cordon d'alimentation ne soit piétiné ou pincé, en particulier au niveau des fiches, des prises de courant, et le point de sortie de l'appareil.
 - 11 Utilisez uniquement des fixations / accessoires spécifiés par le fabricant.
 - 12 Utilisez seulement avec un chariot, stand, trépied, support ou table spécifié par le fabricant, ou vendu avec l'appareil. Lorsque vous utilisez un chariot, soyez prudent lorsque vous déplacez l'ensemble chariot / appareil pour éviter les blessures en cas de chute.
- 
- 13 Débranchez cet appareil pendant un orage ou lorsqu'il est inutilisé storsm pour de longues périodes de temps.
 - 14 Confiez toute réparation à un personnel qualifié. Une réparation est nécessaire lorsque l'appareil a été endommagé de quelque façon que ce cordon d'alimentation ou la fiche est endommagé, du liquide a été renversé ou des objets sont tombés dans l'appareil, l'appareil a été exposé à rail ou à l'humidité, ne fonctionne pas normalement, ou a été échappé.

- 15 10cm distance minimale autour de l'appareil pour une aération suffisante.
- 16 Il convient que l'aération ne soit pas gênée par l'obstruction des ouvertures d'aération par des objets tels que journaux, nappes, rideaux, etc.
- 17 Il convient de ne pas placer sur l'appareil de sources de flammes nues, telles que des bougies allumées.
- 18 Il convient d'attirer l'attention sur les problèmes d'environnement dus à la mise au déchet des piles.
- 19 Si l'appareil est destiné à être utilisé sous un climat tempéré.
- 20 Les batteries ne doivent pas être exposées à une chaleur excessive telle que celle du soleil, d'un feu ou d'origine.

Avertissement

Cet article est lourd. Pour éviter tout risque de blessure, prendre soin lors de la manipulation.

L'appareil ne doit pas être exposé à des éclaboussures et aucun objet rempli de liquide, comme des vases, ne doit être placé sur l'appareil.

Les conduites Plus est utilisé comme dispositif de déconnexion. La fiche de l'appareil ne doit pas être obstruée OU doit être facilement accessible pendant l'utilisation. Pour être complètement déconnecté de l'alimentation électrique, le cordon d'alimentation de l'appareil doit être débranché.

Un appareil avec une borne de terre doit être branché sur une prise de courant en étant relié à la terre.

Attention: Tout changement ou modification non expressément approuvés par la partie responsable de la conformité pourraient annuler l'autorité de l'utilisateur à utiliser cet équipement.

Sécurité Design

Ces appareils sont fournis avec un cordon secteur détachable. Pour le fonctionnement en 230V, un fusible de 4A est installé dans la prise du Planar PL-2 et un fusible de 2.5A dans la prise du Planar PL-1, pour un fonctionnement en 120V, un fusible de 8A est installé pour le Planar PL-2 et un fusible de 5A pour le Planar PL-1. Si le fusible doit être remplacé, utilisez un fusible de même calibre approuvé selon les normes ASTA ou BSI 362. Ne pas utiliser sans le couvercle de fusible en place. Des couvre-fusibles de rechange sont disponibles chez votre distributeur.

FCC STATEMENT

This device complies with Part 15 of the FCC Rules. Operation is subject to the following two conditions:

- 1 This device may not cause harmful interference, and
- 2 This device must accept any interference received, including interference that may cause undesired operation.

NOTE: This equipment has been tested and found to comply with the limits for a Class B digital Device, pursuant to Part 15 of the FCC Rules. These limits are designed to provide reasonable protection against harmful interference in a residential installation.

This equipment generates, uses and can radiate radio frequency energy and, if not installed and used in accordance with the instructions, may cause harmful interference to radio communications. However, there is no guarantee that the interference will not occur in a particular installation. If this equipment does cause harmful interference to radio or television reception, which can be determined by turning the equipment off and on, the user is encouraged to try and correct the interference by one or more of the following measures:

Reorient or relocate the receiving antenna.

Increase the separation between the equipment and receiver.

Connect the equipment into an outlet on a circuit different from that to which the receiver is connected.

Consult the dealer or an experienced radio/TV technician for help.

IMPORTANT: When Planar is not mounted to a wall, it may tip if subjected to force, impact, or climbing. This includes use on the accessory stand or any other freestanding placement.

To reduce the risk of tip-over, an anti-tip restraint system is included. ***REL strongly recommends installing this restraint in all freestanding applications.***

Failure to install the restraint may result in injury or damage.

Welcome to the REL Family

Congratulations on your purchase of your new Planar thin-panel boundary effect subwoofer.

Planar is unlike conventional subwoofers. While most subwoofers are designed to battle room acoustics from somewhere out in the room, Planar is designed to work with the room itself by operating in close relationship with the wall behind it. REL refers to this as boundary effect coupling.

By placing Planar close to the wall, or mounting it using the included hardware, the wall itself becomes part of the acoustic system. This allows Planar to produce deep, powerful bass and remarkable scale from an enclosure only 4.5 in. (130 mm) thick.

Traditional subwoofers often require large cabinets placed well out into the room in order to achieve deep bass and high output. With Planar, we asked a different question: what if a subwoofer could remain close to the wall while still delivering the scale, dynamics, and depth expected from a REL?

The answer is Planar.

Its thin form allows for placement options that are simply not possible with many traditional subwoofers while also helping preserve the openness and usability of the living space. Whether mounted directly to the wall or positioned close to the wall using Planar Cart, Planar is designed to make intelligent use of the surrounding environment to deliver deep, natural bass with minimal intrusion into the room.

Planar was developed for far more than a single type of system or environment. Whether used with traditional stereo speakers, architectural in-wall or in-ceiling systems, open floor plan living spaces, or advanced home theatre installations, the same core principles of placement, integration, and tuning apply.

Throughout this manual, we will guide you through how those principles can be adapted for different applications so your Planar performs naturally and seamlessly within your system.

REL Planar Panel Connection Legend



REL AirShip Direct™ Transmitter

- 1 PAIR Button:** Used to pair REL AirShip Direct™ transmitter with receiver.
- 2 HIGH-LEVEL INPUT (Neutrik® SpeakOn® Socket):** Use to connect HIGH-LEVEL to the main front amplifier speaker terminals.
- 3 BALANCED LFE INPUT (XLR):** Used to connect to the balanced .1/LFE output from a home theatre processor with XLR cables.
- 4 LFE INPUT (RCA):** Used to connect to the .1/LFE output from a home theatre processor. Should be used in conjunction with REL HIGH-LEVEL connection for the ultimate theatre experience.
- 5 PAIR LED:** Indicates whether the REL AirShip Direct™ transmitter is paired with the receiver or not.
- 6 LOW-LEVEL INPUT (RCA):** Used to connect to a stereo output from a stereo pre-amp or home theatre processor.
- 7 PWR Power Switch:** Used to turn on and off REL AirShip Direct™ transmitter.
- 8 DC IN Power Adapter Socket:** DC input socket that accepts a detachable power adapter.



REL AirShip Direct™ Receiver

- 1 **PAIR Button:** Used to pair REL AirShip Direct™ receiver with transmitter.
- 2 **ON/OFF Power Switch:** Used to turn on and off REL AirShip Direct™ receiver.
- 3 **LED:** Indicates whether the REL AirShip Direct™ receiver is paired with the transmitter or not.

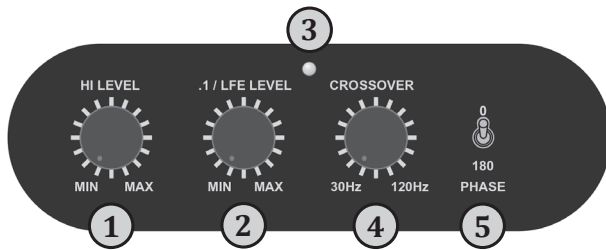

REL Planar Control Panel

- 1 **HI LEVEL Volume Control:** Use to adjust output when using either HIGH-LEVEL or LOW-LEVEL input. Do not use both inputs simultaneously.
- 2 **.1/LFE LEVEL Volume Control:** Use to adjust output level when using .1/LFE input from a 5.1 amplifier or processor.
- 3 **LED Power indicator:** Illuminates white when on, red when in Standby Mode.
- 4 **CROSSOVER Control:** Used to select crossover frequency. Variable between 30 Hz and 120 Hz.
- 5 **PHASE Switch:** Used to set phase 0-180 degrees.

REL Planar Back Panel

- 1 LOW LEVEL INPUT:** Used to connect LOW-LEVEL to the output of a preamplifier, integrated amplifier or receiver **ONLY** when HIGH-LEVEL INPUT cannot be properly connected. (For home cinema, use .1/LFE INPUT).
- 2 .1/LFE INPUT:** Used to connect to the .1/LFE output from a 5.1 amplifier or processor. Should be used in conjunction with REL HIGH-LEVEL connection for the ultimate theatre experience.
- 3 HIGH LEVEL INPUT (Neutrik SpeakOn Socket):** Use to connect HIGH-LEVEL to the main front amplifier speaker terminals.
- 4 STANDBY / ALWAYS ON switch:** Use to set Standby or Always On Mode.
- 5 ON / OFF Power Switch:** Use to turn unit on or off.
- 6 IEC Mains Socket:** Fused mains (AC) input socket that accepts a detachable power cord.



Connecting To Your System

The receiver will come mounted to the side panel of the Planar Sub-Bass System using supplied hardware. In the case that you need to swap a receiver the following information is provided.

Please turn the REL off and make sure that the ON/OFF switch is in the off position before mounting the receiver. Make sure the electrical interface is fully engaged to ensure proper performance and the mounting screws need only be finger tight.

Your Planar PL-1 or PI-2 comes with a REL AirShip Direct™ transmitter that is supplied with each of these subwoofers. Both the Planar subwoofer cabinet and the AirShip Direct™ transmitter will require AC power from a wall plug. There is an AC cable supplied for the subwoofer cabinet and a power adapter cable supplied for the transmitter. The intent here is to find the perfect place for the Planar on a wall with the AirShip Direct™ transmitter located remotely without long cables being needed to deliver the deep bass your Planar is capable of. Simple, seamless, and easy.

Always switch your system off before disconnecting any wires.

To increase the versatility of connection, the Planar models have three separate and distinct types of inputs, although only two will be used as one must decide between HIGH-LEVEL INPUT or a LOW-LEVEL INPUT. They are:

- 1 HIGH-LEVEL INPUT connection which uses a Neutrik SpeakOn terminal.
- 2 .1/LFE INPUT consisting of your choice of RCA or XLR connectors.
- 3 LOW-LEVEL stereo or mono (if using stereo pairs of RELs) inputs. These include RCA connections for stereo input, although if using stereo pairs or Line Arrays of RELs only one input per channel need be used. This is to facilitate use with both two-channel stereo systems as well as AV surround sound systems.

The HIGH-LEVEL, unbalanced, dual-channel (stereo) input is via a Neutrik SpeakOn connector and is designed to accept the stereo (two-channel) signals from the speaker terminals of your receiver, integrated amplifier or basic amplifier. This has the advantage of ensuring that your subwoofer receives precisely the same signal as the main speakers, which means that the character of the bass from the main system is carried forward into the Sub-Bass System.

This is a very important point which, when combined with REL's Naturalsound™ input filters, ensures far superior system integration of your REL Sub-Bass System with the main system.

URGENT NOTE: Plugging in the REL HIGH-LEVEL CABLE. Prior to doing so please STOP and carefully examine the end of the cable's connector. Identify the keyway on the end of the plug and take care to align the keyway with the matching slot on the rear panel SpeakOn HIGH-LEVEL INPUT. To engage the Neutrik SpeakOn plug, insert it carefully into the SpeakOn terminal on the rear panel of your REL and rotate it clockwise until it clicks. If any noticeable resistance is encountered, please stop, reexamine the orientation of the cable's plug to the SpeakOn terminal on your new REL and take care to match the keyway and slot before damage occurs.

How to Properly Detach the REL High-LEVEL CABLE from the REL Sub-Bass System: To remove the Neutrik SpeakOn plug, firmly grip the body of the plug, placing thumb on serrated chrome lever. Slide lever rearward while rotating plug counterclockwise 1/4 turn and withdraw.

XLR and RCA connections are provided for input from the .1/LFE channel of a home cinema processor.

HIGH-LEVEL and .1/LFE inputs can and should be used simultaneously in Theatre Applications. The benefits are two-fold when used with a home cinema processor set to Full Range or as low as your processor or receiver will permit. The .1/LFE INPUT reproduces the .1/LFE channel, and the HIGH-LEVEL connection

underpins the main front speakers. The main front speakers should be set to the 'large' or full range if available option on the AV processor. See "REL Theater Reference™ Home Cinema Applications" for more information (page 18).

There are two RCA sockets for LOW-LEVEL left and right channel connection to the output of a stereo preamplifier or receiver. These may be used in cases where HIGH-LEVEL INPUT is not an option.

We have designed the Planar with connections on the back of the cabinet for users that wish to connect audio using wiring. Should you need to pursue this path, please do NOT attempt to connect using the wireless transmitter as well. It is possible to damage your REL by overdiving the inputs using both of these options. These inputs are simplified to a Neutrik SpeakOn for HIGH-LEVEL INPUT, a phono socket for LOW-LEVEL INPUT and a single phono socket for .1/LFE INPUT.

HIGH-LEVEL INPUT: Connections should be made to the same binding post on main amplifier as the main speakers. Red to amplifier main right speaker red terminal, yellow to amplifier main left speaker red terminal and black to a signal or chassis ground of the amplifier. Plug the Neutrik SpeakOn plug into the HIGH-LEVEL SpeakOn socket.

Note: *This connection does not draw current from the power amplifier and, yes, your REL is a powered Sub-Bass System. However, by deriving its signal from the main power amplifier, better sound quality is achieved.*

.1/LFE INPUT: This requires a RCA to RCA or XLR to XLR cable and is a dedicated true .1 channel. This circuit passes the .1/LFE signal through with only the required 120 Hz filter.

LOW-LEVEL INPUT: This stereo phono input allows for conventional connection from a preamplifier and should be used in the rare event that a HIGH-LEVEL connection proves incompatible. Plug one end of a single phono-phono cable into the LOW-LEVEL INPUT jack of the REL and the other end into either the left or right channel output of your preamplifier. A second Planar may be purchased to fully integrate with your stereo speakers if using low level out, as in active loudspeakers.

These connections can be made on the Planar through the REL AirShip Direct™ transmitter. Using input connections to both the REL AirShip Direct™ transmitter and direct to the Planar back panel are not permitted.

PHASE SWITCH: Used to set phase

Position 0 / HIGH-LEVEL, LOW-LEVEL or LFE: 0 degrees phase

Position 180 / HIGH-LEVEL, LOW-LEVEL or LFE: 180 degrees phase

PHASE SELECTION AFFECTS BOTH HIGH-LEVEL AND LOW-LEVEL INPUTS

CROSSOVER is always engaged for HIGH-LEVEL INPUT. The .1/LFE signal does not pass through the crossover circuit.

Making Connections

It is helpful to know that you will almost always connect the REL to the input on the rear panel labeled **HIGH-LEVEL INPUT**. This connection is made to the REL AirShip Direct™ transmitter using the supplied 4.9' (1.5 meter) cable, the bare leads of which connect to the speaker output terminals of the power amplifier. The easy and foolproof connection at the REL is done with a Neutrik SpeakOn connector. The purpose of connecting to the speaker output terminals is one of the unique secrets of REL's success. By connecting to the high-level input on the REL from the amplifier, you build forward the sonic signature of your main system, including the tonal balance and timing cues of the entire electronics chain. In this way, the REL is fed the exact signal that is fed to the main speakers.

Connecting

HIGH-LEVEL connection, using the enclosed cable with the Neutrik SpeakOn connector, is always the first choice. This connection can be made without affecting the performance of the amplifier because the REL's amplifier input impedance is 150,000 ohms, in effect producing NO additional load on the rest of your system.

- The standard HIGH-LEVEL hook up procedure is attaching the red wire to the amplifier's right positive speaker output terminal; attach the yellow wire to the amplifier's left positive speaker output terminal; attach the black wire to whichever of the amplifier's chassis ground screws or bolts is convenient; plug the SpeakOn connector into the Sub-Bass System's HIGH-LEVEL INPUT.

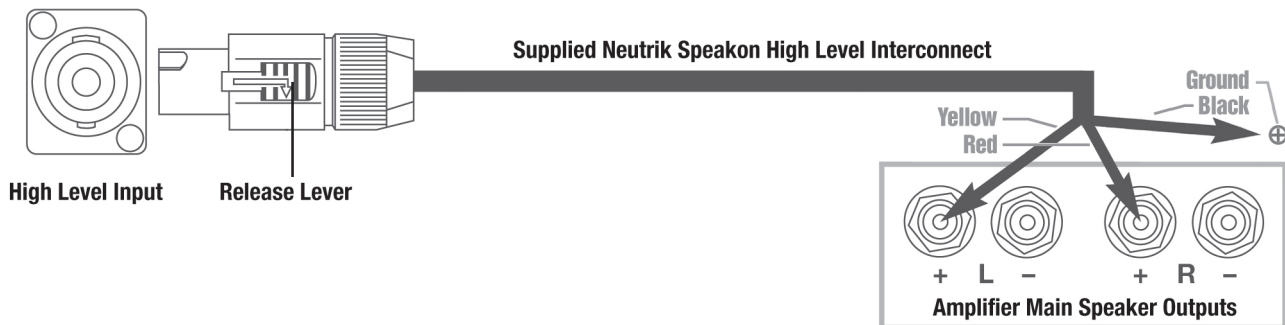

- For differential (i.e. fully balanced) stereo amplifiers using one REL, simply use the standard connecting scheme of connection to an exposed chassis ground screw or bolt. It may also be allowed to “float” or hang down without connection to ANY terminal. Should hum occur using this method, please return to connecting to chassis ground or an unused RCA connector on the rear of a preamp or amplifier. Please contact your dealer should there be any questions concerning this or any other hookup procedure.

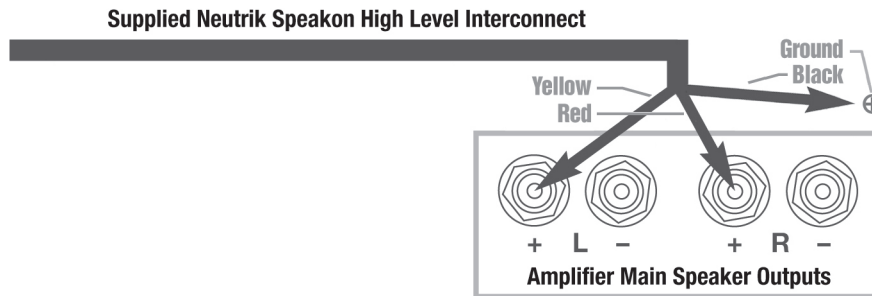

NOTE: *The REL AirShip Direct™ transmitter is equipped with internal circuitry to allow seamless connection to Class-D (digital) main amplifiers. If connecting to a Class-D amplifier, follow the above connection procedure for differential amplifiers.*

When connecting RELs to Mono Bloc amplifiers (2) RELs, one for each amplifier, must be used. Connect the black wire of each REL to chassis ground screws or bolts of the corresponding amplifier channel; twist together the red and yellow wires of each REL separately and connect each pair to the positive speaker terminal of the corresponding amplifier channel. In some instances, this will result in exceptionally high gain (output) from the RELs. If it seems simply too high in gain, please remove either the red or yellow wire from the twisted pair. This will reduce output by half and restore a natural dynamic.

Supplied Neutrik Speakon High Level Interconnect

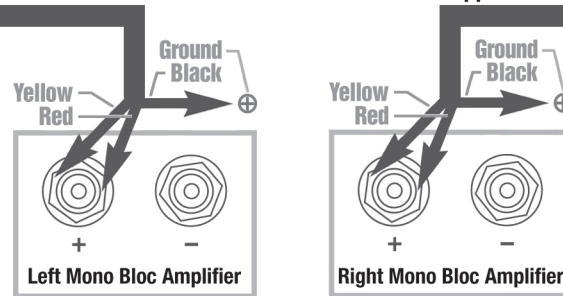

If connecting a single REL as a dedicated centre channel sub, twist together the red and yellow wires and connect these paired wires (red/yellow paired together) to the positive centre channel amplifier terminal. Connect the black wire to a ground lug or chassis screw on the amplifier.

Supplied Neutrik Speakon High Level Interconnect

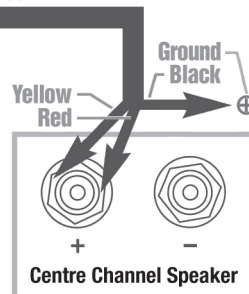

If connecting a REL as a dedicated rear channel sub, connect the yellow wire to the left rear positive speaker terminal; connect the red wire to the right rear positive speaker terminal, connect the black wire to a ground lug or chassis screw. If the amplifier is of balanced differential design, please follow the instructions in the section above labeled Differential Connection.

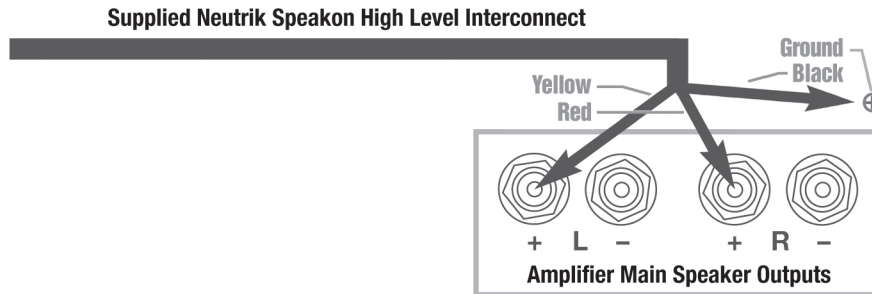

LOW-LEVEL connection (via RCA connectors) is always an option if HIGH-LEVEL connection is not possible. When connecting to the low-level inputs in a system in which HIGH-LEVEL connection is not possible, such as if using internally amplified speakers, connect left and right RCA cables between the LOW-LEVEL INPUT jacks of the REL and the left and right channel outputs of your preamplifier.

When connecting to a home cinema system where a .1/LFE channel output is present, connect a single phono or XLR cable between the sub output of the processor/receiver and the .1/LFE input jack on the AirShip Direct™ wireless transmitter.

REL Theatre Reference™ Home Cinema Applications

For home theatre systems, once the standard set-up for two-channel outlined above is complete, the LFE output from the processor or receiver should be connected to the .1/LFE input and appropriate volume adjustments made using the .1/LFE LEVEL control. For this configuration, you must set the processor to the “large” or “full range” setting for the left and right speakers in order for the REL to receive the bass signal via the HIGH-LEVEL CABLE. In this configuration, the REL provides support for both the left and right speakers for two-channel listening, and support for the LFE when films are playing. Most processors will allow you to defeat the subwoofer output when listening in the two-channel mode. The effect of this set-up is one of greatly increased dynamics in the mid-bass range, no bass bloat, and a greater degree of space and timing from the special audio effects.

Pairing

Now that the AirShip Direct™ wireless transmitter is connected to your amplifier (ideally using the HIGH-LEVEL CABLE), unpack the Planar subwoofer and place on a clean sheet or towel to protect finish.

Each Planar comes pre-paired with its REL AirShip Direct™ transmitter box. If the units need to be re-paired, or you would like to add more Planar subs to the system, there are a few easy steps to follow.

REL Planar wireless Sub-Bass Systems come paired to a single transmitter out of the box. In the event that the sub and transmitter becomes un-paired, the owner must follow the procedure below to repair.

- 1 Make sure that the transmitter's AC to DC wall plug supply is connected to an AC outlet, and that the barrel connector is connected to the transmitter. A white LED on the control panel of the transmitter will indicate the unit is on by blinking in the standby pattern which is one flash per second.
- 2 Make sure that the sub is plugged into an AC outlet using the supplied AC cable and that the sub is turned on. Power switch is located on the rear panel.
- 3 Exercise the momentary PAIR switch on the transmitter located on its control face. This will make the transmitter look for a new sub. Note that the LED flash pattern will change to two blinks per second.
- 4 Next exercise the momentary PAIR switch on the receiver located on the side panel.
- 5 At this point the sub and transmitter should find each other and pair together. This will be indicated by the white LEDs on both the transmitter and control panel staying constantly on (no flashing).

The REL Planar wireless sub bass system can pair up to four subwoofers using one transmitter. To pair more than one sub to a single transmitter, follow the instructions above and repeat for each subwoofer added.

Status	LED Indicator
Paired	Continuously on
Searching	Blinks twice per second
Standby	Blinks once per second

When using two transmitters with two independent systems in proximity to each other (within the same house):

- 1 Follow the pairing instructions above for the first system.
- 2 Turn off the first transmitter.
- 3 Follow the pairing instructions above for the second system.
- 4 Turn the transmitter on for the first system back on.

Each Planar will come out of the box independently paired to its own AirShip Direct™ transmitter and will not have issues with “cross talk.” However, if there is a problem, re-pairing each Planar for independent operation should eliminate cross talk.

REL Set-Up Made Simple

Now that you have the AirShip Direct™ transmitter box connected to your amplifier and wirelessly paired to Planar, it is time to choose a location and dial in Planar for your specific room. This section will help guide you in selecting the best location and choosing the basic settings for Planar, but will not discuss installation. The installation process will be discussed in detail in the next section.

Before You Begin

- 1 Planar is unlike any other REL Sub-Bass System and therefore requires special considerations for placement. Planar is designed to be mounted on the wall and will take advantage of the entire wall to help generate deep bass pressurization.
- 2 Planar can be mounted to masonry or sheetrock walls. For sheetrock walls, it is NECESSARY that Planar is anchored/screwed into studs in order to properly support long term use. The specialized brackets developed just for Planar require mounting *BOTH upper and lower right side screws into a stud as well as the upper bracket's left side*. The lower bracket comes supplied with an insert that must be GLUED and screwed into the wall. If one chooses not to use glue, expect rattles to develop.
- 3 Studs are structural members behind the surface of modern walls. There are generally two types of studs, wood or metal (typically aluminum). Usually there is a sheet of pre-manufactured building material, often referred to as sheetrock or gypsum rock, layered over the top of studs.
- 4 If you do not know where the studs in your wall are located use a “studfinder” (an inexpensive electronic tool that uses electronic pulses to locate denser objects, like studs, behind the sheetrock).
- 5 If your wall is constructed out of a different material that does not use sheetrock and studs, see the next section in the manual *Setting Up Your REL Planar Sub-Bass System*, steps number 5 and 6 (page 25) for more details. You may have a wider selection of locations for installation.
- 6 Next we will discuss selecting the best location and proper settings for Planar. *Remember, Planar Sub-Bass Systems MUST be mounted to studs for 3 of the bolts and please use the supplied metal augur-shaped wall anchor so you will need to find the best sounding location that coincides with two (2) wall studs.*

Warning: Planar Sub-Bass Systems must NOT be ceiling mounted under any circumstances. This is extremely dangerous as they can fall and injure someone.

Setting Up Your REL Planar Sub-Bass System

Part I will discuss how to select the best location for Planar:

Always set the Planar on a clean sheet or towel to protect the finish.

1 Preparing to Mount your Planar for wall mounting: This means that your first order of business is to locate your preferred studs, then decide which will perform best, both sonically and from a practical perspective. This is quite simple. Using a standard stud finder locate and using blue painter's tape (*leaves no residue*) carefully mark the outer edges of each stud by placing tape carefully along the inside edge of each stud). In many instances this will result in no more than 3-4 stud bays that have both studs and an AC mains outlet located conveniently nearby within range of the supplied power cable.

Front Wall: Understand that the best sounding locations will usually be on the wall that is immediately behind your speakers. This often yields the best deep bass and assures excellent integration of Planar's deep bass with your primary speakers.

Side Wall: Side walls can work very well, but there is far more variation in output from side walls. For this reason, our guidance in Front Wall (*above*) will generally provide the best overall sonic performance. When choosing side walls locations more extensive experimentation of locations for mounting Planar may be necessary in order to arrive at a mounting location (*still has to be mounted firmly into studs*) that produces good bass performance at your primary listening position.

Start by bolting top bracket cabinet and bottom bracket cabinet to the rear of your Planar using supplied screws from package A. Take care to fine tune positioning to ensure they are as parallel with cabinet top as possible. Having these brackets installed allows you to approximate the correct distance from the wall your Planar will sit when installed and therefore allow for more accurate listening results.

Then connect the power cable to the unit and turn it on because you will need to listen while positioning. If you are using the wireless connection, the transmitter will have to be connected to the system and paired with the unit. If hard wiring, these connections will need to be made to the back of the cabinet.

2 Positioning: The goal of this step is to pick the best wall to position Planar on a Planar Cart or when mounting on a wall. If you already know which wall you want to install the Planar on, move to step 3. As you experiment with different wall choices, try to hold Planar so that the bottom of the unit is 10 to 12in. (25 to 30 cm) off the ground. This will provide an approximate location (we will review left/right and up/down exact placement next) and allow you to judge the merits of each position. Remember, while you may have several wall choices the availability and location of studs will impact your decision.

Front Wall Mounting: Mounting Planar on the front wall of the room, in other words, the wall that the main speakers are positioned in front of will generate the best sonic results (same concept with conventional subwoofers). Front wall placement allows for the most linear true low bass wave launch, creates the best sense of pressurizing the room, and creates the best sense of keeping time and tempo with the music.

Side Wall Mounting: Side wall mounting works well also, just not quite as well as front wall mounting. Nevertheless, quite high levels of performance are available from the side wall location, as long as the subwoofer is located in the range between the front corner and the speaker location. In some instances, it may be fine to place the Planar slightly in front of the main speaker (towards the listener), but moving it too far along the side wall will result in the listener's ability to locate it, reducing the seamless integrative abilities inherent to the REL design.

If you are still unsure about which wall to choose and have several options with possible stud locations move on to step 3 which will further guide your decision.

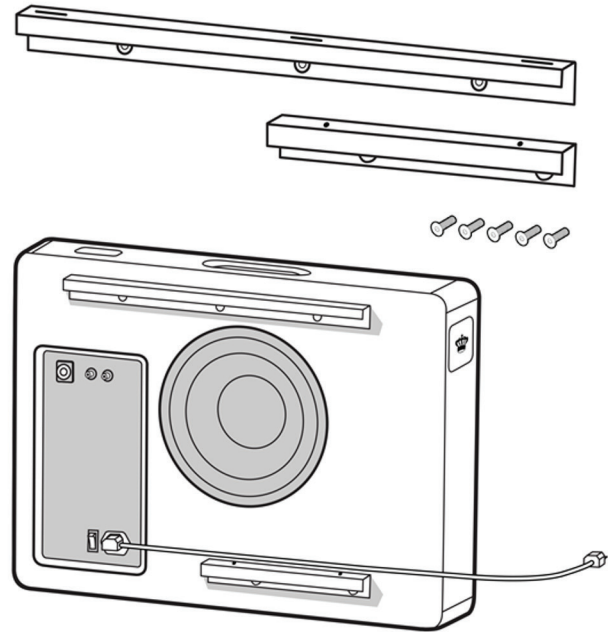

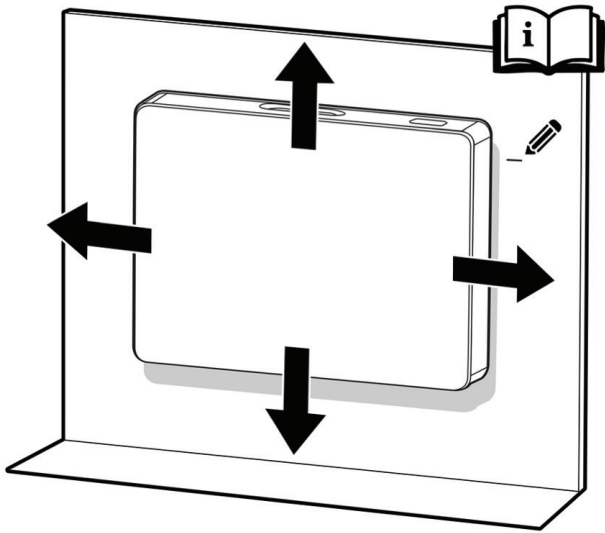

3 Left/Right (Horizontal) Location: Now that you have selected the wall for the Planar it is time to determine the left/right location on the wall. In some cases you will only have one option (or limited options – typically standard walls only offer 2-3 useful locations) based where the studs are located. Keep the stud locations in mind as you complete this step because they dictate how much movement left/right you have to experiment with. Move the Planar along the wall in the left/right plane stopping at each possible stud location with the Planar approximately three feet off the ground and the bracket distance away from the wall. Listen for the best bass pressurization, extension, and integration at each location. Remember,

if you are using the side wall we suggest that you locate the Planar behind the main speakers if possible (in the range between the front corner and the speaker location).

If you are still unsure about which stud to choose on a particular wall and have several options move on to step 4 which will further guide your decision.

4 Up/Down (Vertical) Location: Up until this point we have suggested holding the Planar so that the bottom of the unit is approximately 10 to 12in. (25 to 30 cm) off the ground. While this is a good estimate to use while choosing the wall and left/right location, to obtain the best possible performance the up/down location placement is essential. Just as you did previously, play a well-known piece of music with consistent, repetitively struck bass impulses and begin moving Planar up and down the line of the stud (make sure to locate the edge of the bracket installed on the Planar to the stud location). Slowly moving the subwoofer up the stud line on the wall, note and mark (lightly—no need to mark up your wall permanently) where the bass is strongest. At first, this may seem subtle, however, after doing it for a short time you should start to hear these stronger pulses quite clearly.

If you were previously unsure about which stud location to choose and have several options do this up/down listening test for all possible locations and compare the results. This will help you make the best overall decision.

User Hint: *If using an AV processor/receiver with the REL HIGH-LEVEL cable make sure the speakers are set to “Large” or “Full Range” in the settings menu.*

5 Selecting Location When Using Masonry Walls (Brick or Cement-based Building Blocks): All of the same notes and suggestions apply to locating Planar in a room built using masonry. However, you are no longer limited by stud locations resulting in far more choices in placement. Use the same voicing technique described above, and note that front wall placement still generally results in the best overall performance.

6 Selecting Location When Using Plaster Walls: Plaster walls represent special challenges since the plaster itself is exceptionally brittle. Unless you have extensive experience working with plaster walls, it is recommended that installation of Planar be performed by an experienced professional. Use the same voicing technique described above, and note that front wall placement still generally results in the best overall performance.

Positioning Using Planar Cart 1 or 2

Begin by installing your Planar on its Cart, using the instructions supplied with the Cart. Make sure to install the grille prior to installing it on the Cart as you will find it impossible to do so once it is bolted to the Cart.

When used in a freestanding configuration, REL strongly recommends installation of the included anti-tip restraint system. *See the “Stability & Anti-Tip Safety” section in this manual (page 38).*

The Process PL-2 model: To begin dialing in crossover, phase and gain please acquire the CD of the 1994 movie *Sneakers* (the streaming version which has inferior bass dynamics) and use track four from the soundtrack to *Sneakers* (Columbia CK 53146). This has a repetitive bass drum throughout that gives you plenty of time to move the woofer around, but more importantly, the concert bass drum is pitched at 32 Hz. This track is perfect for dial-in of PHASE and CROSSOVER and will get you close on gain. The overall system volume should be at a level that a reasonable person would describe as medium or medium loud volume level.

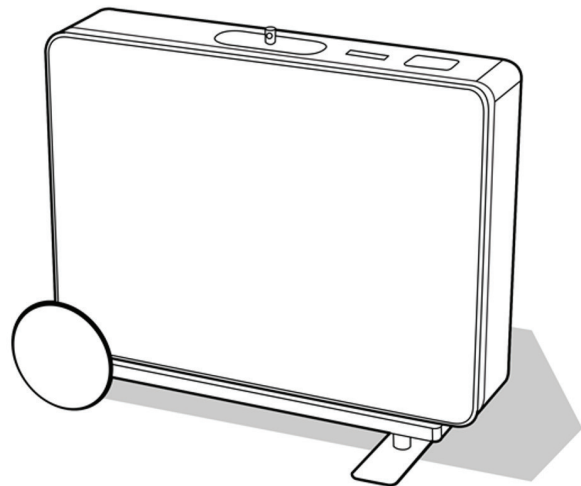

The Process for PL-1 Model: All the same directions both above and below are identical with the exception of our guidance to use Rachelle Ferrell Cut *Sista* from her cd *“Individuality: Can I be Me?”*. This difference of setup material is necessary because the Planar PL-2 extends significantly deeper and we find that the same results can be achieved on PL-1 with different program material. Set the controls to the following settings: Adjust the HI LEVEL to a point where the Planar and speaker are sure to share frequencies (*about halfway up or slightly higher for smaller speakers*). Turn the HI LEVEL Gain control up so that the output of your Planar and speakers are roughly equal in volume. For many speakers, this will be in the region of **9 to 11 o’clock**. We recommend using the HIGH-LEVEL connection to obtain the best results.

Working with a partner, one in the listening position and one at the Planar subwoofer manipulating its controls and varying location, is the most effective and efficient way to dial in your Planar when used as an on-wall. If working alone, the initial step in the set-up can be very effectively carried out from the location of the Planar, however prior to making a final determination first narrow your selection to the two best sounding, then listen to each from your primary listening position. Trying to ignore all other music in the track, listen for the bass drum and its effect on the listening room.

1 PHASE 0 or 180?: Place Planar on the floor near the wall (*use a clean and soft towel or blanket to protect the bottom finish*) using the installed bracket length away from the wall. Adjusting for phase may be the single most critical step and, because it really is quite simple, it is often over-thought. Keep in mind that the correct phase is whichever position produces the loudest output. Do not make the mistake of selecting the wrong phase simply because you believe it sounds more delicate or “prettier”. Louder is correct because it is working with your speaker’s phase, not cancelling bass. Less bass occurs when it’s set incorrectly because the incorrect phase setting results in cancellation of energy.

2 Crossover and Level Settings: REL controls have detents you can feel when rotating them. We refer to these as clicks and use them to guide positions of these controls. To determine the crossover point, take the volume of the REL (using the HI LEVEL control) all the way down, and set the CROSSOVER to its lowest setting. While playing Cut 4 of Sneakers, begin bringing the REL's Level control up one click at a time and pause at the point where you have achieved balance, i.e. the point at which you can hear the REL even with the main speakers playing. Now, bring the crossover control up (clockwise) 1 click at a time until it is obviously too high; at this point bring it down to the appropriate lower setting. This may be 1 click higher or lower than you initially felt was right. For all intents and purposes, this is the correct crossover point. Once this stage has been reached, subtle changes to LEVEL and CROSSOVER can be made to provide the last bit of complete and seamless integration.

Hint: *There is a tendency to set the crossover point too high and the volume of the Sub-Bass System too low when first learning how to integrate a REL with the system, the fear being one of overwhelming the main speakers with bass. But in doing so, the resulting set-up will be lacking in bass depth and dynamics. The proper crossover point and volume setting will increase overall dynamics, allow for extended bass frequencies, and improve soundstage properties. Note that volume must be adjusted in conjunction with crossover changes whenever one is increased check to ensure that the other doesn't need to be reduced by one click. In general, when selecting a lower crossover point, more volume level can be applied.*

3 Final Checks: Now that your Planar has the proper settings, confirm that you are satisfied with the wall location you previously chose by lifting it up in place as a final check. If you are satisfied, you are now ready to install the Planar as an on-wall subwoofer. Be sure to revisit step 2 after you have properly installed the Planar to make subtle changes to the crossover and gain settings.

Other use cases

The primary use of Planar is to reinforce front left and right stereo speakers, but it can also be used in home theatre and to reinforce inwall speakers. Connection instructions for these other use cases are available in the previous section of this manual, "Making Connections" (page 15).

Centre Channel

The Planar (particularly the PL-1) can be used as a dedicated centre channel subwoofer in a home theatre system. The ideal placement is below or behind the centre channel speaker on the front wall. Connect HIGH-LEVEL only, there is no need for Low Frequency Effects (LFE). For dedicated centre channel connection instructions, *see the Making Connections section (page 15)*. Begin with a lower crossover setting than used for the main front channels and gradually increase the HI LEVEL control until dialogue gains weight and scale without sounding thick or unnatural. While adjusting settings, listen carefully to spoken dialogue and the sense of space around voices and on-screen effects. If dialogue begins sounding chesty or disconnected from the screen, reduce the crossover or output level.

Rear Channel

Planar may also be used as a dedicated rear channel subwoofer in home theatre systems. The approach to using the Planar with the rear channel of a home theatre is similar to the front channels, in that it will provide low-frequency support for these specific speaker channels while also reinforcing LFE events. If only one Planar is used in the front, it is best to place the rear Planar in the opposite corner. If stereo pairs of Planar are used in the front, stereo rear Planars are recommended for best balance. For rear channel applications, use both the HI LEVEL and .1/LFE INPUTS simultaneously. For connection instructions, *see the Making Connections section (page 15)*. Begin with lower output settings than used for the front channel Planars and adjust gradually. While tuning, listen for smooth movement of bass effects from the front to rear of the room and a greater sense of space and immersion. If bass becomes distracting or easily localized to the rear of the room, reduce output level or crossover frequency.

In Wall and In Ceiling Speakers

In-wall and in-ceiling speakers often lack low-frequency extension and dynamic weight. Planar can be used to restore balance and scale to these systems. Planar placement, connection, and tuning generally follows the same process described earlier in this manual. Whenever possible, front wall placement is recommended for the best integration and overall performance. For music-focused systems, use the High-Level connection. For systems used for both music and home theatre, use both the HI LEVEL and .1/LFE INPUTS simultaneously. *See the Making Connections (page 15) and REL Set-Up Made Simple sections (page 21)* for setup and connection instructions. While adjusting crossover and level settings, listen for improved weight, scale, and integration in the overall system without drawing attention to the Planar itself. If the bass becomes overly dominant or detached from the main speakers, reduce crossover or output level.

Mounting

Before beginning the installation process, read the REL Setup Made Simple section (page 21) for instructions about how to select the best location for Planar.

The following step by step instructions guide a Planar user in mounting the cabinet to a typical home wall made of studs with drywall finish or brick masonry walls. The Planar must be securely anchored to the wall. There are two sets of mounting brackets for the Planar cabinet. Each set is made up of a wall side bracket and a cabinet side bracket that are designed to fit together to create a solid mounting for the Planar.

Stud Wall Mounting

The top bracket spans most of the length of the cabinet and should get mounted to two studs that are 400mm (16in.) apart. The bottom bracket is shorter and should get anchored to one stud and a sturdy drywall mount. Both brackets are required for the Planar to function properly. *Two people are recommended for proper installation.*

Supplied Hardware

- Top Bracket Wall (long wall bracket)
- Top Bracket Cabinet (long cabinet bracket)
- Bottom Bracket Wall (short wall bracket)
- Bottom Bracket Cabinet (short cabinet bracket)

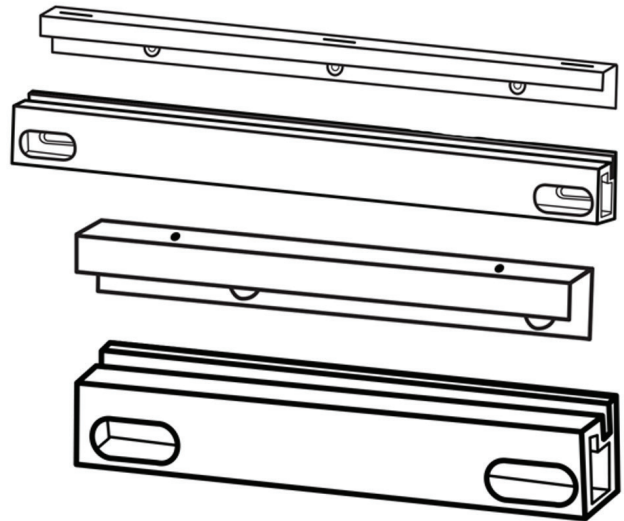

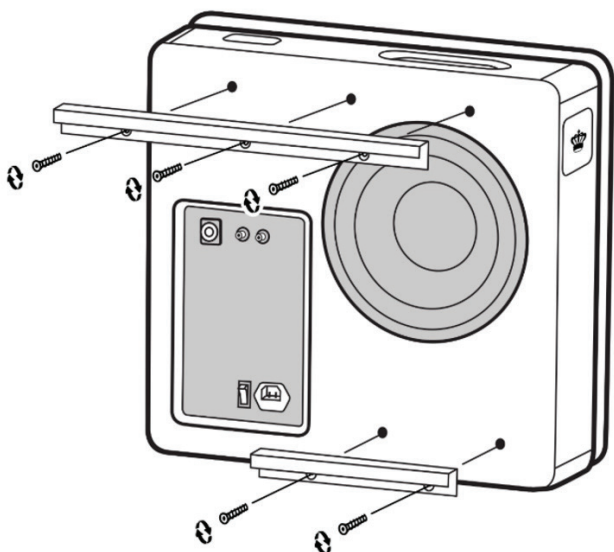
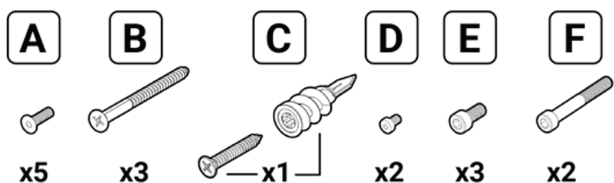

- A Flat head screw M6 thread, 4mm hex drive, 18mm length (x5)
- B Flat head wood screw Size 8, 1-3/4in. length (X3)
- C Self drilling #9 drywall anchor with flat head wood screw Size 9, 1-1/4in. length
- D Socket cap screw M3 thread, 2.5mm hex drive, 8mm length, pre-installed on bracket (x2)
- E Socket cap screw M6 thread, 5mm hex drive, 14mm length (x3)
- F Socket cap screw M6 thread, 5mm hex drive, 50mm length (x2)

- Gasket long
- Gasket short
- Wall mount template
- 4mm hex driver
- 5mm hex driver

Required (not supplied)

- Philips screwdriver
- Pencil
- Drill / driver
- 3/32in. drill bit
- 14in. ruler or tape measure
- Level
- Glue
- Stud finder
- Medium adhesion painter's tape

- 1 Remove grille and set aside on a clean surface.
- 2 Mount cabinet side brackets (Top and Bottom) to the cabinet using flat head screws. This step should have been completed in the *REL Setup Made Simple* section.

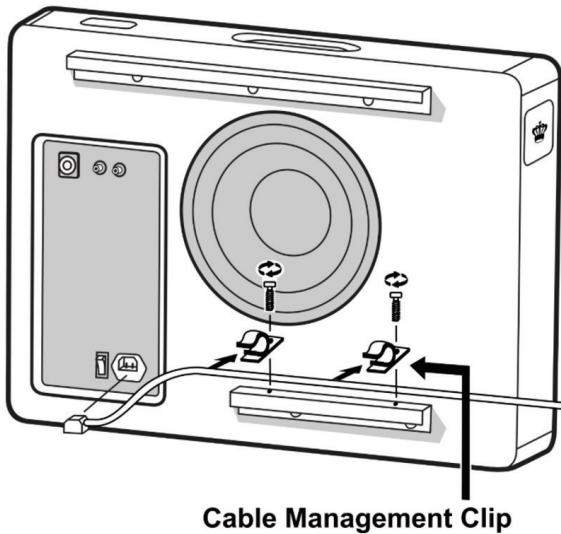
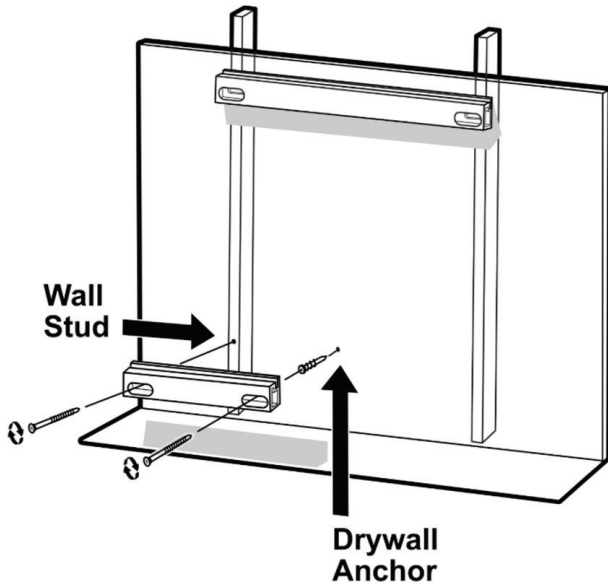
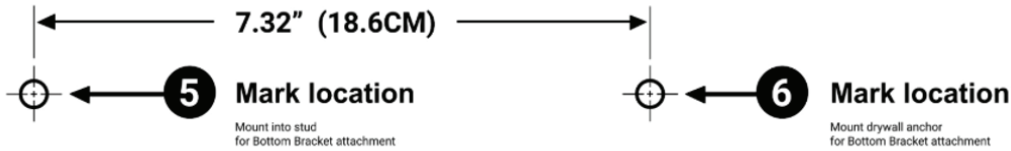

- 12 The left side screw hole for bottom wall bracket should be directly below that of the top bracket and there should be a wall stud behind it.
- 13 Drill a pilot hole for the two screw holes using the drill / driver and 3/32in. drill bit.
- 14 The right screw hole will require a drywall anchor. Use glue on the threads when installing this anchor to the drywall. The type of anchor supplied will cut its own hole as you screw it in.
- 15 Place short gasket on the back side of wall bracket C. Gasket must go between wall and bracket. Do not omit the use of this gasket.
- 16 Screw bottom bracket to wall with drywall screws. Make sure screws are tight and bracket is mounted solid to wall but not compressing the gasket.
- 17 Connect AC cable provided to back panel of Planar and install AC cable clips to dress the cable along the bottom bracket. Remember to turn the AC switch on because this will be difficult once the Planar is mounted.
- 18 Lift cabinet to wall and lower onto brackets.

- 19 The fit will be snug. Draw the cabinet into place using the three 18mm long cap head top mounting hardware. Tighten the three provided screws 1/2 turn at a time starting with one side and rotating through each one. Using this method will take several passes to get the screws tight. You will notice that with each pass the Planar is evenly pulled into the bracket.
- 20 Secure bottom bracket with the two 50mm long cap head hardware provided from the bottom side of the bracket.
- 21 Install Grille.

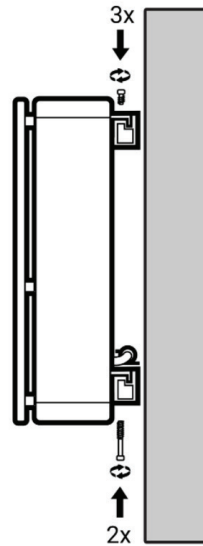

Now that the Planar subwoofer is mounted to the wall, it is time to revisit the settings to really dial in the system.

Crossover and Level Settings: To determine the crossover point, take the volume of the REL (using the HI LEVEL control) all the way down, and put the CROSSOVER to 25 Hz. At this point bring the REL's volume back up slowly to the point where you have achieved a subtle balance, i.e. the point at which you can hear the REL even with the main speakers playing. Now, bring the crossover point up until it is obviously too high; at this point bring it down to the appropriate lower setting. For all intents and purposes, this is the correct crossover point. Once this stage has been reached, subtle changes to level and crossover can be made to provide the last bit of complete and seamless integration.

Hint: *There may be a tendency to set the crossover point too high and the volume of the Sub-Bass System too low when first learning how to integrate a REL with the system, the fear being one of overwhelming the main speakers with bass. But in doing so, the resulting set-up will be lacking in bass depth and dynamics. The proper crossover point and volume setting will increase overall dynamics, allow for extended bass frequencies, and improve soundstage properties. Note that volume must be adjusted in conjunction with crossover changes. In general, when selecting a lower crossover point, more volume may need to be applied.*

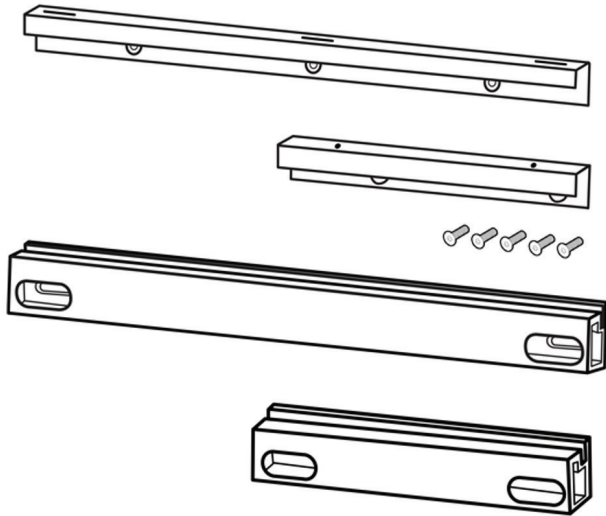

A



x5

D



x2

E



x3

F



x2

Solid Wall Mounting

Before beginning the installation process, read the REL Setup Made Simple section for instructions about how to select the best location for Planar.

Wall anchors will be required to screw the top and bottom brackets to the wall. The supplied set of brackets should work with all types of solid walls. Both brackets are required for the Planar to function properly. Two people are recommended for proper installation.

Supplied Hardware

Top Bracket Wall(long wall bracket)

Top Bracket cabinet (long cabinet bracket)

Bottom Bracket Wall (short wall bracket)

Bottom Bracket cabinet (short cabinet bracket)

A Flat head screw M6 thread, 4mm hex drive, 18mm length (x5)

D Socket cap screw M3 thread, 2.5mm hex drive, 8mm length, pre-installed on bracket (x2)

E Socket cap screw M6 thread, 5mm hex drive, 14mm length (x3)

F Socket cap screw M6 thread, 5mm hex drive, 50mm length (x2)

Gasket long

Gasket short

Self drilling #9 drywall anchor

Wall mount template

4mm hex driver

5mm hex driver

Required (not supplied)

Philips screwdriver

Pencil

Drill / driver

14in. ruler or tape measure

3/16in. masonry drill bit

5/16in. masonry drill bit

Glue

Medium adhesion painter's tape

Hammer

Size 8 Masonry anchors (X4)

Level

1 5/8in. fine thread drywall screws (x4)

(This is a suggested length. Your wall may require longer screws)

1 Remove grille and set aside on a clean surface.

2 Mount cabinet side brackets (Top and Bottom) to the cabinet using flat head screws. This step should have been completed in the REL Setup Made Simple section.

3 Determine placement of the Planar. *See the REL Setup Made Simple section of this manual.*

4 Holding the cabinet in place on the wall, mark the wall along the top edge of the top bracket and at the right corner.

5 Next hold Top Wall bracket to the wall below the mark from the top bracket.

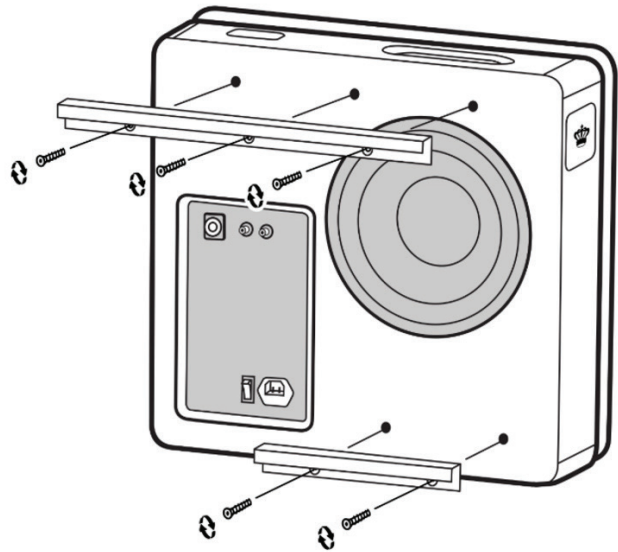

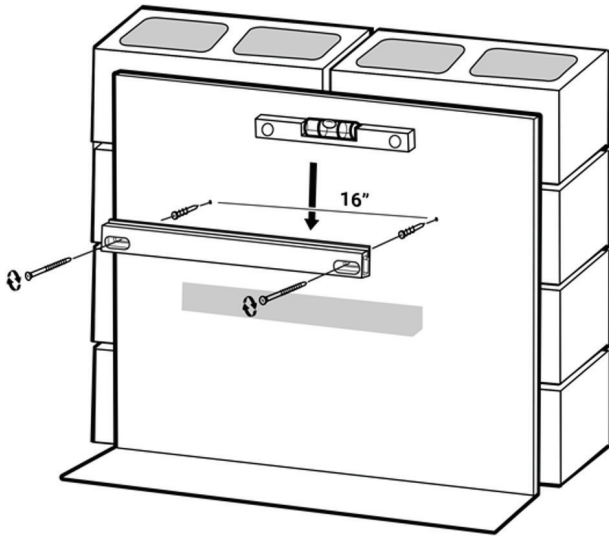

Template
(This Document)

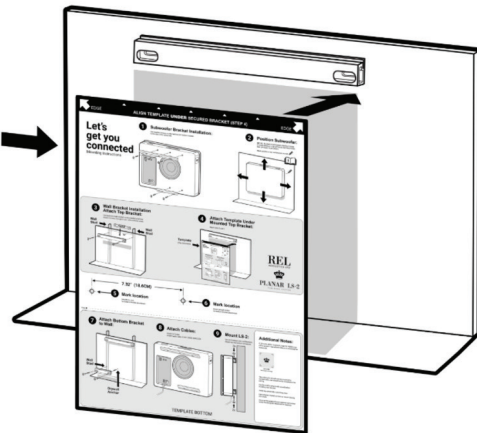

- 6 Level the bracket against the wall and mark the screw hole locations.
- 7 Drill a pilot hole for each screw hole using the drill / driver and 3/16in. drill bit.
- 8 Drill hole for anchors using the drill / driver and 5/16in. drill bit.
- 9 Put glue on masonry anchors before installing.
- 10 Push masonry anchor into wall and drive flush with hammer.
- 11 Place long gasket on the back side Top Bracket Wall. Gasket must go between wall and bracket. Do not omit the use of this gasket.
- 12 Screw top bracket to wall using screws. Make sure screws are tight and bracket is mounted securely to wall but not compressing the gasket.
- 13 With top wall bracket in place, use the supplied wall mount template to locate the holes for the bottom bracket. This template should work for all solid walls. Place template directly under top wall bracket and mark the holes indicated for your wall construction.
- 14 Drill a pilot hole for the two screw holes using the drill / diver and 3/16in. drill bit.
- 15 Drill hole for anchors using the drill / driver and 5/16in. drill bit.

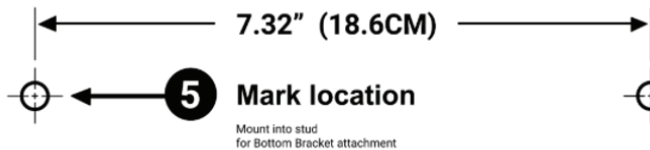

7.32" (18.6CM)

5 **Mark location**

Mount into stud
for Bottom Bracket attachment

6 **Mark location**

Mount drywall anchor
for Bottom Bracket attachment

- 16 Put glue on masonry anchors before installing.
- 17 Push masonry anchor into wall and drive flush with hammer.
- 18 Place short gasket on the back side of Bottom Bracket Wall. Gasket must go between wall and bracket. Do not omit the use of this gasket.
- 19 Screw bottom bracket to wall using screws. Make sure screws are tight and bracket is mounted securely to wall but not compressing the gasket.
- 20 Connect AC cable provided to back panel of Planar and install AC cable clips to dress the cable along the bottom bracket. Remember to turn the AC switch on because this will be difficult once the Planar is mounted.
- 21 Lift cabinet to wall and lower onto brackets.
- 22 The fit will be snug. Draw the cabinet into place using the three 13.5mm long cap head top mounting hardware. Tighten the three provided screws 1/2 turn at a time starting with one side and rotating through each one. Using this method will take several passes to get the screws tight. You will notice that with each pass the Planar is evenly pulled into the bracket.
- 23 Secure bottom bracket with the two 50mm long cap head hardware provided from the bottom side of the bracket.
- 24 Install Grille

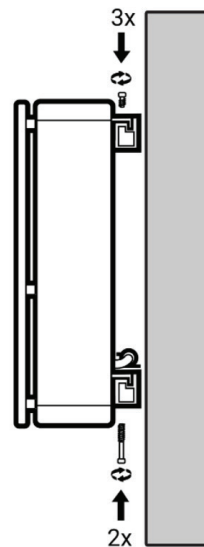
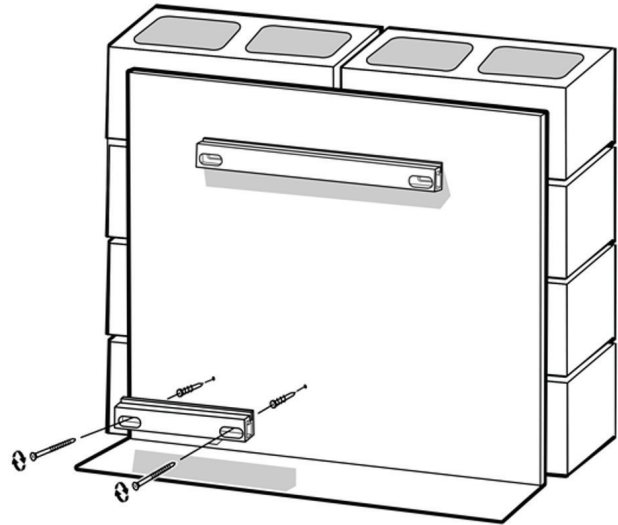

Now that the Planar Sub-Bass System is mounted to the wall, it is time to revisit the settings to really dial in the system.

Crossover and Level Settings: To determine the crossover point, take the volume of the REL (using the HI LEVEL control) all the way down, and put the CROSSOVER to 25 Hz. At this point bring the REL's volume back up slowly to the point where you have achieved a subtle balance, i.e. the point at which you can hear the REL even with the main speakers playing. Now, bring the crossover point up until it is obviously too high; at this point bring it down to the appropriate lower setting. For all intents and purposes, this is the correct crossover point. Once this stage has been reached, subtle changes to level and crossover can be made to provide the last bit of complete and seamless integration.

Hint: *There may be a tendency to set the crossover point too high and the volume of the Sub-Bass System too low when first learning how to integrate a REL with the system, the fear being one of overwhelming the main speakers with bass. But in doing so, the resulting set-up will be lacking in bass depth and dynamics. The proper crossover point and volume setting will increase overall dynamics, allow for extended bass frequencies, and improve soundstage properties. Note that volume must be adjusted in conjunction with crossover changes. In general, when selecting a lower crossover point, more volume may need to be applied.*

Stability & Anti-Tip Safety

Planar is designed to be mounted to a wall or used in close relationship with a wall for optimal performance. When used in a freestanding position, it may tip if subjected to sufficient force.

REL strongly recommends installing the included anti-tip restraint in all freestanding applications, especially in environments with children, pets, or high foot traffic.

Installing the Anti-Tip Restraint

The Anti-Tip Restraint is comprised of a wall tether block that will mount onto the back of your Planar Sub-Bass System's cabinet, hardware that will screw into your wall, and a tether that will anchor these pieces together. For safe operation when Planar is used in a freestanding position, install the included anti-tip restraint as follows:

- 1 Secure the wall tether block to the subwoofer's cabinet, using the supplied bolts (two from package A). This block and the bolts are designed to mount to the centre and upper-right inserts found on the rear face of the Planar subwoofer's cabinet.
- 2 Secure the two included loose anchors to your wall. Each anchor uses two screws for securing to the wall. We recommend marking the screw locations with a pencil, drilling pilot holes using a 6mm drill bit, then pressing the plastic drywall anchors into the pilot holes. You can then screw in the metal anchors.
- 3 Once the anchors are installed onto your wall and the tether block is installed onto the subwoofer, you can use the two supplied cables for securing each anchor on the block to the corresponding anchor on your wall.

Use of the anti-tip restraint is the primary method of preventing tip-over when Planar is used in a freestanding position.

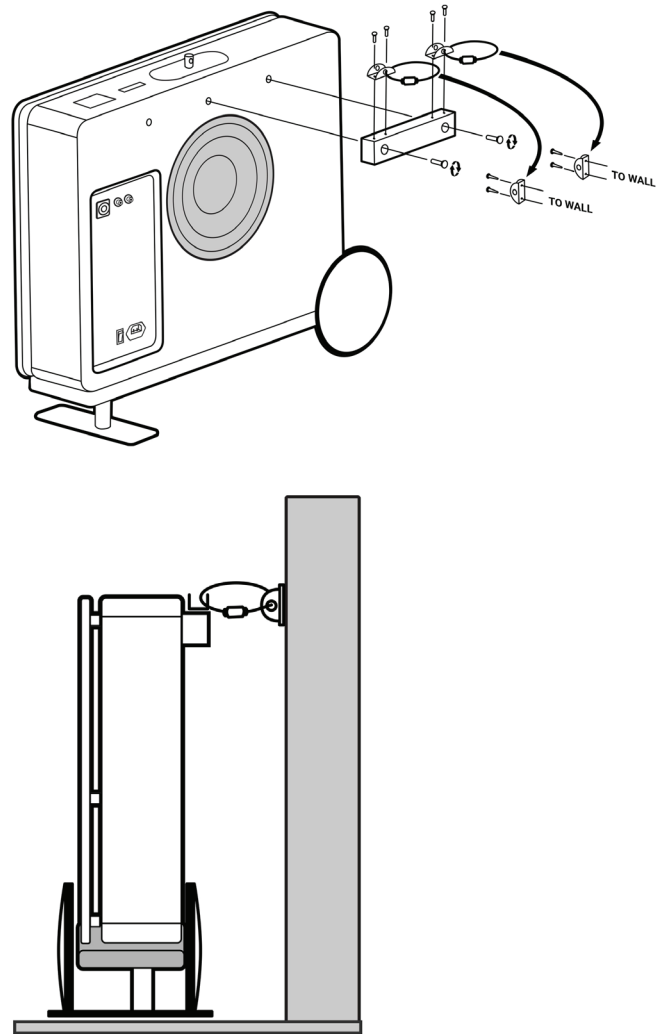

Running In

Care taken over running in will be rewarded by many years of pleasurable use. Both the electronics and the drive unit will benefit from an initial period of carefully controlled use. Possible damage may be sustained by running in the unit at too high a volume setting over an extended period. On the other hand, by taking a little care over this initial period, about 24 hours of actual use, a longer life with an eventual higher potential performance is assured.

Care and Polishing

The cabinets are best maintained by using a light automotive spray-on wax and a micro fiber cloth. (We use a spray-on made by a company called Griot's Garage™. While this may not be available in all markets, you can use a similar product). Take care not to spray the aluminum badge. Do not place objects, such as drinks on top of your REL Planar. Never use a dry cloth on this finish.

Technical

The AirShip Direct™ transmitter provides true REL Theatre Reference™ connectivity, permitting both HIGH-LEVEL and LFE channels to be wirelessly fed to Planar. This occurs with virtually zero delay and a complete absence of compression.

Planar uses a very fast, gentle and transparent filter intended to allow excellent impulse response and a natural sound. We refer to this circuit as Natural Rolloff™. Most subs use slow, very steep filters that lend an unnatural, machine-like quality to the sound. The Planar employs a highly refined Class-D amplifier which combines high performance and high efficiency. The drivers are simple, rugged and relatively light, and yet offers excellent self-damping so we are better able to reproduce the nuance of music and preserve the explosiveness of transients. Finally, the cabinets, apart from being physically beautiful, are like finely tuned instruments that are largely responsible for the sonic virtue with which the Planar is imbued.

PL-1 Specifications

Type:	(2) Front-firing active woofers, (1) Rear-firing passive radiator
Drive Unit:	(2) 6.5in. (165mm) FibreAlloy cone, long-throw, steel chassis
Passive Unit:	10in. (250mm) FibreAlloy cone, steel chassis
Lower Frequency Response:	-6 dB at 31 Hz, in room
Input Connectors:	HIGH-LEVEL Neutrik SpeakOn, LOW-LEVEL RCA, LFE RCA
Gain Control Range:	80 dB
Power Output:	300 watts (RMS)
Phase Switch:	Yes, 0 or 180 degrees
Amplifier Type:	Pure Class D™
Protection System:	Fully Electronic SET-SAFE
D.C. Fault:	Yes
Output Short:	Yes
Mains Input Voltage:	100-240 volts selectable
Fuse:	2.5A for 230V operation 5A for 120V operation
Dimensions (WHD):	20.6 x 19.4 x 5.7in. (522 x 492 x 144mm) add 1.5in. (39mm) depth for on wall bracket
Net Weight:	41.6lbs. (18.9 kg)
Finish:	Gloss Piano Black or Gloss White Lacquer
Supplied Accessories	
Mains Lead:	Yes, 90 degree to permit on wall mounting
Neutrik SpeakOn Interconnect:	Yes. 1.5m cable intended for use with AirShip Direct™ transmitter
User Manual:	Yes

PL-2 Specifications

Type:	(1) Front-firing active woofer, (1) Rear-firing passive radiator
Drive Unit:	8in. (205mm) FlatPiston™ active long-throw, steel chassis
Passive Unit:	10in. (250mm) FibreAlloy cone, steel chassis
Lower Frequency Response:	-6 dB at 24 Hz, in room
Input Connectors:	HIGH-LEVEL Neutrik SpeakOn, LOW-LEVEL RCA, LFE RCA
Gain Control Range:	80 dB
Power Output:	550 watts (RMS)
Phase Switch:	Yes, 0 or 180 degrees
Amplifier Type:	Pure Class D™
Protection System:	Fully Electronic SET-SAFE
D.C. Fault:	Yes
Output Short:	Yes
Mains Input Voltage:	100-240 volts, selectable
Fuse:	4A for 230V operation 8A for 120V operation
Dimensions (WHD):	25.6 x 18.9 x 5.7in. (650 x 480 x 144mm) add 1.5in. (39mm) depth for on wall bracket
Net Weight:	44.6lbs. (20.25 kg)
Finish:	Gloss Piano Black or Gloss White Lacquer
Supplied Accessories	
Mains Lead:	Yes
Neutrik SpeakOn Interconnect:	Yes 1.5m cable intended for use with AirShip Direct™ transmitter
User Manual:	Yes

AirShip Direct™ Transmitter Specifications

Input Connectors:	HIGH-LEVEL Neutrik SpeakOn, L/R LOW-LEVEL RCA, LFE single phono RCA, LFE balanced XLR
Input Impedance	
HIGH-LEVEL:	150k ohms
LOW-LEVEL:	10k ohms
RCA .1/LFE:	10k ohms
XLR .1/LFE:	10k ohms
Wireless output power:	Less than -3dBm
Wireless effective distance:	30 ft (10 meters) with clear line of site
Mains Input Voltage:	5V DC, 5.5mm circular connector, positive centre
Power consumption:	0.6 Watts
Dimensions (WHD):	Transmitter 8.5 x 8.5 x 1.8in., (215.5 x 215.5 x 46.5mm) Receiver 3.15 x 2.40 x 0.7in., (80 x 60 x 17.5mm)
Finish:	Black
Supplied Accessories:	Power adapter, HIGH-LEVEL cable, X2 RCA cable

What Comes Packed with Planar Series Subwoofers

PL-1 or PL-2 Subwoofer

Cloth Grille

Airship Direct Wireless System (with receiver unit pre-installed on subwoofer)

Right-Angle Power Cord

Control Panel Cover

Owner's Manual

Wall Mounting Template

Wall Mounting Brackets

VIMAR Material for Wall Mounting

One (1) 4mm Allen/Hex Wrench

One (1) 5mm Allen/Hex Wrench

Flat head screw M6 thread, 4mm hex drive, 18mm length (x6)

Socket cap screw M6 thread, 5mm hex drive, 50mm length (x2)

Socket cap screw M6 thread, 5mm hex drive, 14mm length (x3)

Self drilling #9 drywall anchor (x2)

Flat head wood screw Size 9, 1- $\frac{3}{4}$ in. length (x2)

Flat head wood screw Size 8, 1- $\frac{3}{4}$ in. length (x4)

Two (2) Cable Retainer Clips, pre-installed to lower bracket

REL Acoustics Limited

North Road, Bridgend industrial Estate . Bridgend, CF31 3TP . United Kingdom

Telephone: +44 (0)1 656 768 777 . Fax: +44 (0) 1 656 766 093

Web: www.rel.net